



10

THE WORLD'S MOST ADVANCED  
INSTRUMENTS FOR TEXTILE AND BIOPHYSICAL TESTING

# HOTPLATE - MATTRESS (ST2-XL)

Thermal and moisture management testing in the larger subjective area of seating and sleeping comfort presents a particular challenge to industrial designers, especially with the composite nature of the materials involved.

The ST-2XL Comfort Test System is a device developed to support and simplify in-house testing procedures and to help evaluate the need for more advanced thermal instrumentation tests.

The ST-2XL can be used on various seating and sleeping surfaces including mattresses, couches and

seat cushions to evaluate the thermal properties and moisture management characteristics of materials.

It can be quickly and easily positioned as needed to evaluate the regional effects of different cover materials or internal construction methods - even with highly insulated products such as mattresses and cushioned furniture.

The carbon-epoxy unit contains one thermally controlled zone, and a computer-controlled fluid supply system that simulates metabolic perspiration levels.





## ST-2XL Specifications

- 15 in. x 15 in. square active surface, suitable for representation of seated anatomical contours
- Device Dimensions: 18 x 18 x 3.25 in. H (46 x 46 x 9 cm. H)
- Power Requirements: Single phase, 50/60 Hz, 85-265 VAC
- Carbon-fiber construction with distributed resistance wire sensors
- Two temperature controlled guard zones
- Ultra-stable resistance wire heating
- One computer-controlled sweating zone
- Network of pores across the test zone are used to deliver water to the skin surface
- Includes sweat distribution pump, reservoir, UV water purification, and connection tubing
- One ambient RH sensor
- DHS dynamic sensor technology
- Signal conditioning electronics
- Power and control cabling
- 800 W/m<sup>2</sup> maximum power output
- ± 0.1°C thermal accuracy
- ± 1% power measurement accuracy
- ± 3% relative humidity measurement
- Variable (10°C - 40°C) temperature setpoints
- 0–1000 ml/(hr-m<sup>2</sup>) perspiration rate

## Base Products Include:

- Hot plate with heaters and sensors
- Control electronics
- Two ambient temperature sensors
- Laptop loaded with ThermDAC control software
- Power and control cabling
- One relative humidity sensor
- Standard one-year warranty

## ST- 2XL Feature Highlights & Benefits

- Evaluate the thermal properties and moisture management characteristics of mattresses, cushions, and a variety of bedding and seating materials
- Lightweight and portable yet ruggedly built, the ST-2XL is designed to simulate bed/seat compression rates that are equivalent to a 175 pound person
- DHS dynamic sensor technology - generates instantaneous surface heat-flux measurements
- Thermally conductive carbon fiber test zone and guard, with ultra-stable resistance wire heating for accurate and uniform heat flux
- Integrated sweating system with computer-controlled fluid supply
- Fluid supply includes UV light and filter for improved reliability and reduced maintenance
- System includes a laptop PC with exclusive ThermDAC control software featuring full thermal control, fault detection, real-time data display, and data logging capabilities

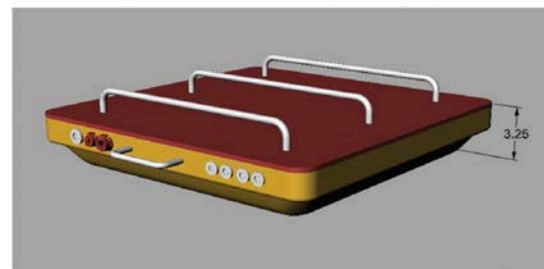
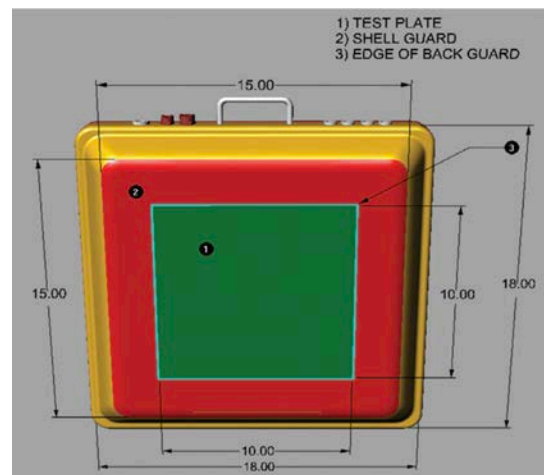



**ThermDAC Control Software**

ThermDAC is an engineered user interface for thermal manikin systems providing real-time device control, automated testing, and flexible display and logging capabilities, including:

- Real-time display of instrument data and user control of device outputs
- User-programmable test configurations, tolerances, and stability criteria
- Automatic steady-state detection
- Zoomable time-history graph of multiple device and ambient variables
- Real-time statistical analysis over any user-selected time range
- Logging of raw data, statistical analysis, integrated report generation
- Device calibration and fault detection

316 - Hotplate - Mattress (ST-2XL)	Item #	Description	Product Name
Standard Base Product	19-31601	Mattress Tester - ST-2XL	316-XXX
Standard Option	20-01054	ST-2XL Calibration Cradle Assembly	—

 *Don't see what you need above? Contact Thermetrics to customize your perfect system. Keep your ST-2XL in tip-top shape. Discuss service plan options and point-of-sale discounts with us at [sales@thermetrics.com](mailto:sales@thermetrics.com).*